

PLAN VIEW
PREFERRED OPTION

FINISHED
PAVEMENT

2" DIA. BRASS SURVEY MARKER,
SURVEYOR IDENTIFICATION TO BE
STAMPED ON MARKER FACE.
REFER TO SHEET 4 OF 4 FOR
ADDITIONAL INFORMATION

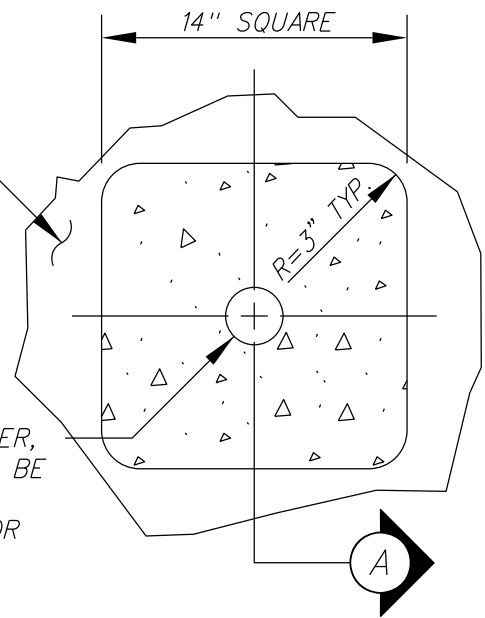

PLAN VIEW
ALTERNATE OPTION

TOP OF CONCRETE FINISHED
FLUSH WITH TOP OF
ADJACENT PAVEMENT.

2" DIA. BRASS SURVEY MARKER
(FLUSH W/CONC.)(SEE SHEET 4 OF 4)

1/8" R. (TYP.)

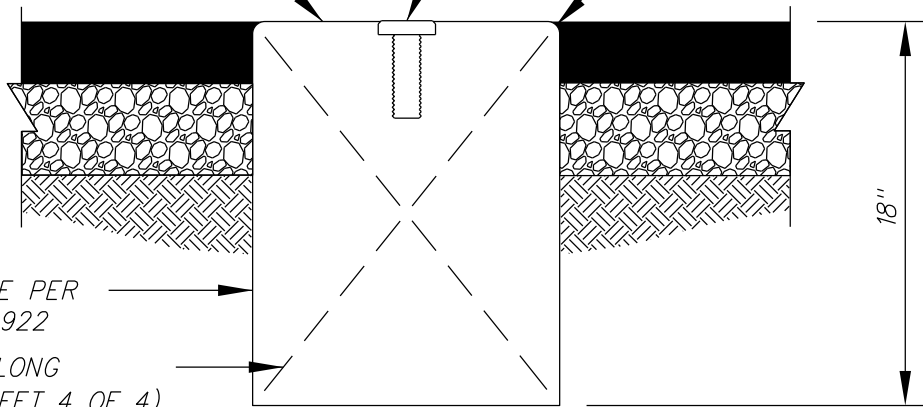

UTILITY CONCRETE PER
PAG STD. SPEC. 922
2-#4 BARS, 16" LONG
(SEE NOTE #7 SHEET 4 OF 4)

A SECTION

ISSUED:

10/88

REVISED:

11/16



STANDARD DETAIL

SURVEY MONUMENT



DETAIL NO.

103

SHEET 1 of 4

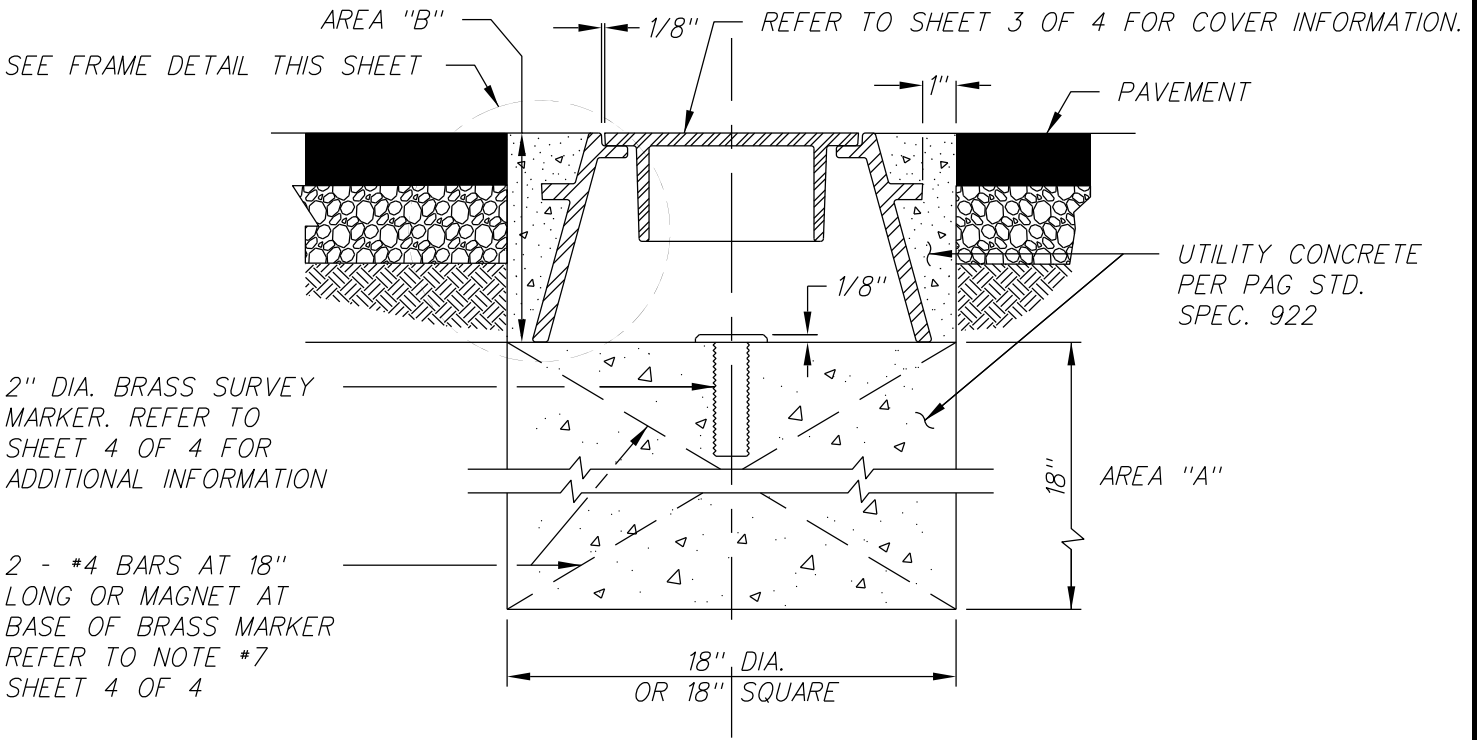

FRAME AND MONUMENT

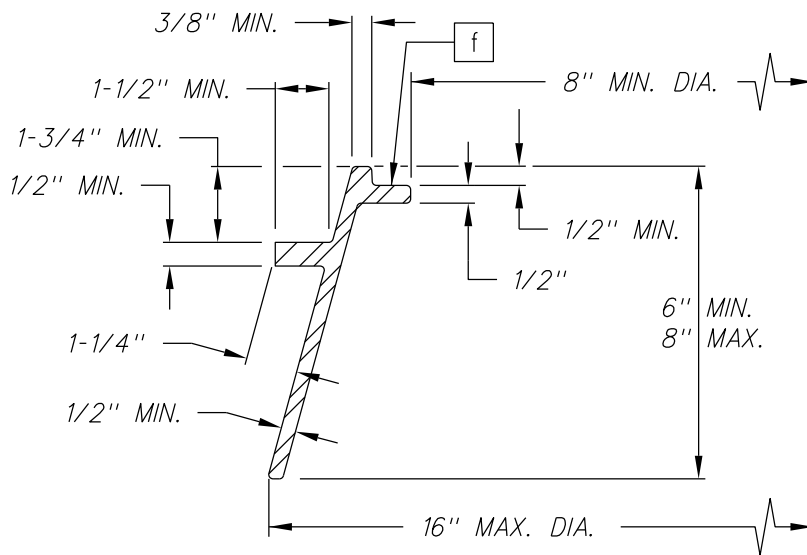

FRAME

NOTE:

DIMENSIONS NOT SHOWN PER THE MANUFACTURER

NOTES:

1. SURVEY MARKER, FRAME AND COVER, COMPLETE-IN-PLACE, SHALL BE CONSIDERED A SINGLE UNIT.
2. FRAME AND COVER SHALL BE FIRST CLASS GREY IRON, TOUGH AND EVEN GRAINED.
3. FRAME AND COVER TO BE TRAFFIC RATED.
4. FRAME TO BE SET ON CONCRETE AND LEFT FREE TO SLIDE.
5. BRASS MARKER TO BE SET BY CONTRACTOR AND MARKED BY SURVEYOR.
6. SURVEYORS REGISTRATION NUMBER TO BE STAMPED ON BRASS CAP.
7. AREA "B" TO BE PLACED AFTER AREA "A" HAS ACHIEVED INITIAL SET.
8. PORTIONS OF THE FRAME TO BE MACHINE FINISHED ARE SHOWN BY THE SYMBOL f. THE ALLOWABLE TOLERANCE FOR MACHINED AREAS SHALL BE 1/64".

ISSUED:

10/88

REVISED:

11/16



STANDARD DETAIL

SURVEY MONUMENT
(FRAME AND COVER)



DETAIL NO.

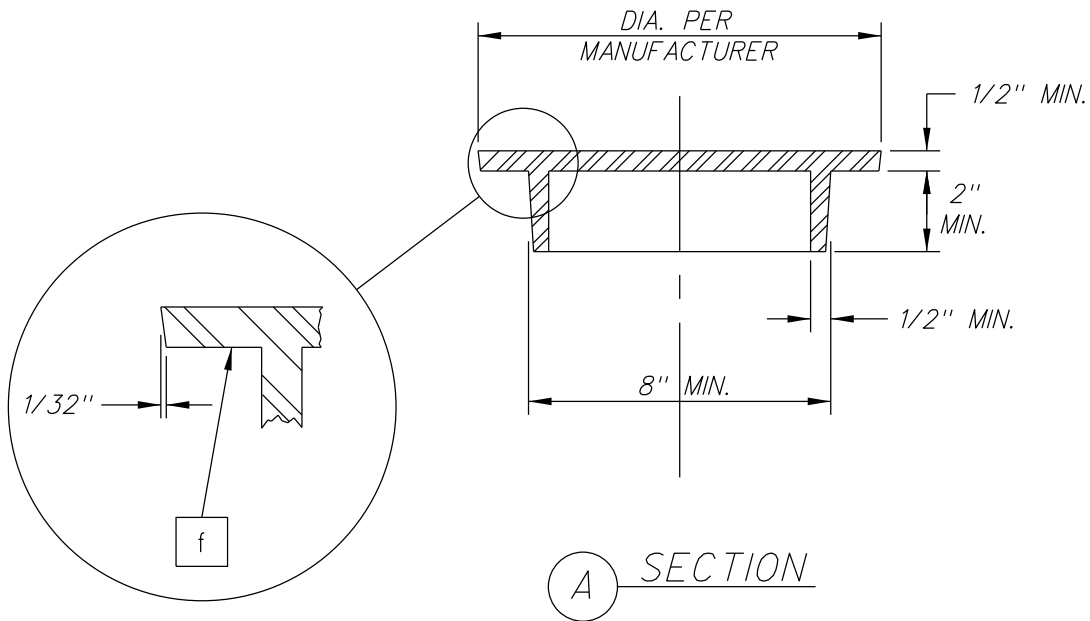
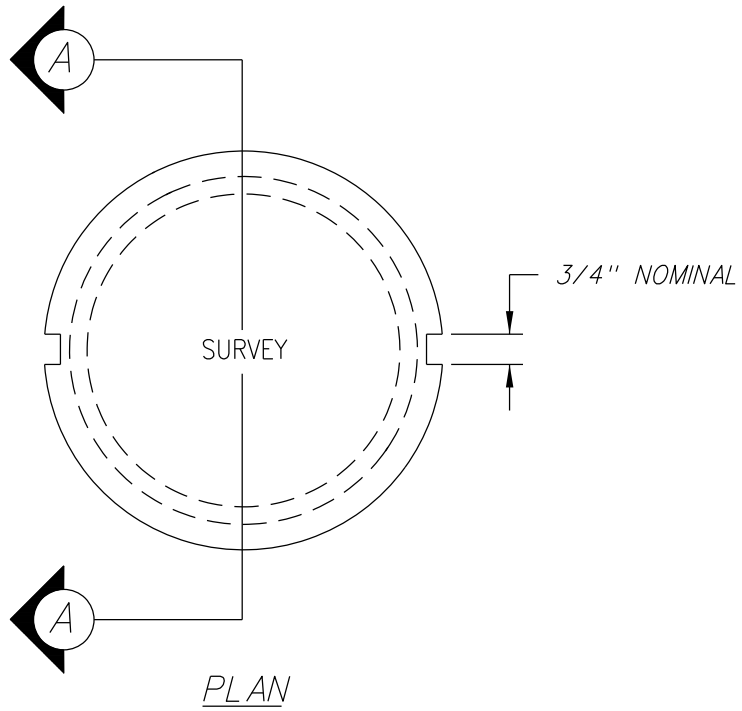

103

SHEET 2 of 4



NOTES:

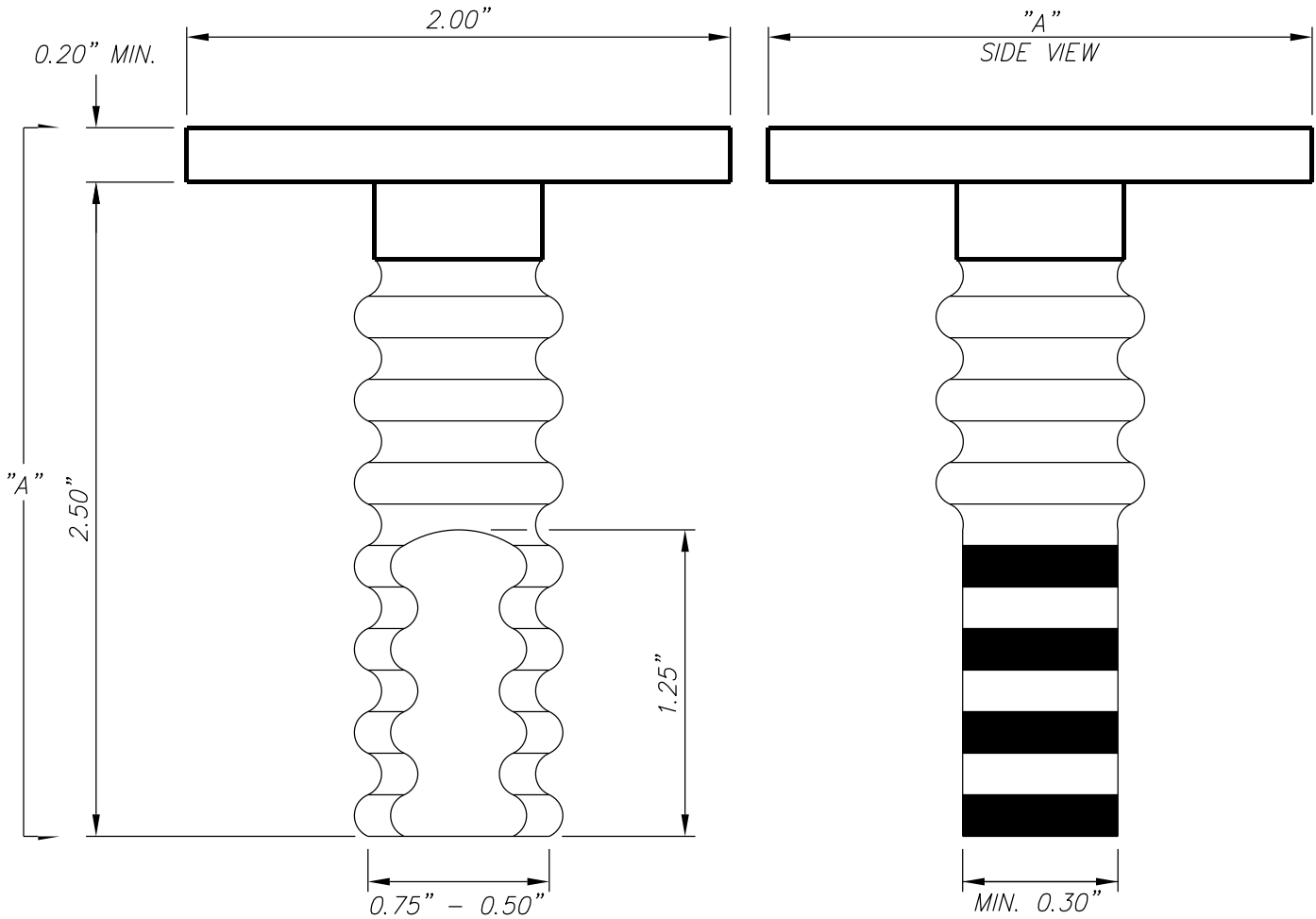

1. COVER SHALL BE TRAFFIC RATED.
2. LETTERS ON COVER SHALL BE BLOCK 5/8" X 3/4" AND RAISED 1/16" AND 1/8" WIDE.
3. PORTIONS OF THE COVER TO BE MACHINE FINISHED ARE SHOWN BY THE SYMBOL, f, THE ALLOWABLE TOLERANCE FOR MACHINED AREAS SHALL BE 1/64".

ISSUED:		STANDARD DETAIL		DETAIL NO.
10/88		SURVEY MONUMENT		103
REVISED:		(COVER)		SHEET 3 of 4
11/16				



GENERAL NOTES:

1. SURVEY MARKER MAY BE USED WITH SURVEY MONUMENT AS A BENCH AND SURVEY CONTROL MARKER.
2. SURVEY MARKER SHALL BE MADE OF RED BRASS MATERIAL MEETING THE REQUIREMENTS OF ASTM B283/ B283 M-16.
3. SHANK GEOMETRY SHALL PROVIDE FOR SECURE ANCHORAGE IN CONCRETE SUCH AS A SPLIT, TAPERED, THREADED, FLARED OR FLUTED STYLE STEM.
4. WHEN USED TO DEFINE SECTION LINES, THE MARKER SHALL BE STAMPED IN ACCORDANCE WITH THE BLM "MANUAL OF SURVEYING INSTRUCTIONS" INCLUDING THE LAND SURVEYOR'S REGISTRATION NUMBER.
5. BENCH MARK STATION, ELEVATION, YEAR, AND/OR OTHER INFORMATION SHALL BE HAND STAMPED IN THE FIELD, AS APPROVED BY THE ENGINEER.
6. TEXT SHALL NOT OBSCURE SURVEY POINT.
7. THE 2-#4 BARS MAY BE REPLACED BY A MAGNET OF A SIZE APPROVED BY THE AGENCY, PLACED AT THE BASE OF THE BRASS MARKER.
8. BRASS MARKER TO BE SET BY CONTRACTOR AND MARKED BY SURVEYOR.
9. REGISTERED SURVEYOR'S IDENTIFICATION TO BE STAMPED ON MARKER FACE.

ISSUED:		STANDARD DETAIL		DETAIL NO.
10/88		SURVEY MONUMENT		103
REVISED:		(SURVEY MARKER)		SHEET 4 of 4
11/16				